

- > **Port size: DN 8 ... 50, G1/4 ... 2 (ISO G/NPT)**
- > **High flow rate**
- > **Damped operation**
- > **Functional compact design**
- > **Solenoid interchangeable without tools (Click-on®)**



### Technical features

**Medium:**

Neutral gases and liquids

**Switching function:**

Normally closed

**Operation:**

Indirectly solenoid actuated

**Mounting position:**

Optional, preferably solenoid vertical on top

**Flow direction:**

Determined

**Port size:**

G1/4, G3/8, G1/2, G3/4, G1, G1 1/4, G1 1/2, G2

1/4 NPT, 3/8 NPT, 1/2 NPT

3/4 NPT, 1 NPT, 1 1/4 NPT,

1 1/2 NPT, 2 NPT

**Operating pressure:**

See table

**Fluid temperature:**

-10° ... +90°C (+14° ... +194°F)

**Ambient temperature:**

-10° ... +50°C (+14° ... +122°F)

**Material:**

Body: Brass (CW617N)

Seat seal: NBR

Internal parts: Stainless steel, PVDF

For contaminated fluids insertion of a strainer is recommended.

### Technical data - standard models

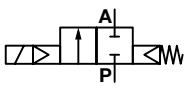
Symbol	Port size	Orifice (mm)	Valve length (mm)	Flow kv value *1) (m <sup>3</sup> /h)	Operating pressure *2) (bar)	Weight (kg)	Model Solenoid in V d.c./a.c.
	G1/4	8	60	1,9	0,1 ... 16	0,47	8240000.9101.xxxxx
	1/4 NPT	8	60	1,9	0,1 ... 16	0,47	8241000.9101.xxxxx
	G3/8	10	60	3	0,1 ... 16	0,45	8240100.9101.xxxxx
	3/8 NPT	10	60	3	0,1 ... 16	0,45	8241100.9101.xxxxx
	G1/2	12	67	3,8	0,1 ... 16	0,5	8240200.9101.xxxxx
	1/2 NPT	12	67	3,8	0,1 ... 16	0,5	8241200.9101.xxxxx
	G3/4	20	80	6,1	0,1 ... 16	0,65	8240300.9101.xxxxx
	3/4 NPT	20	80	6,1	0,1 ... 16	0,65	8241300.9101.xxxxx
	G1	25	95	9,5	0,1 ... 16	0,95	8240400.9101.xxxxx
	1 NPT	25	95	9,5	0,1 ... 16	0,95	8241400.9101.xxxxx
	G1 1/4	32	132	23	0,1 ... 10 (16) *3)	2,73	8240500.9101.xxxxx
	1 1/4 NPT	32	132	23	0,1 ... 10 (16) *3)	2,73	8241500.9101.xxxxx
	G1 1/2	40	132	25	0,1 ... 10 (16) *3)	2,53	8240600.9101.xxxxx
	1 1/2 NPT	40	132	25	0,1 ... 10 (16) *3)	2,53	8241600.9101.xxxxx
	G2	50	160	41	0,1 ... 10 (16) *3)	3,85	8240700.9101.xxxxx
	2 NPT	50	160	41	0,1 ... 10 (16) *3)	3,85	8241700.9101.xxxxx

xxxxx Please insert voltage and frequency codes

\*1) Cv-value (US) ≈ kv value x 1,2

\*2) For gases and liquid fluids up to 25 mm<sup>3</sup>/s (cSt)

\*3) With Solenoid 9151

Option selector

824\*\*\*\*\*.\*\*\*\*\*

Thread form	Substitute
ISO G	0
NPT	1
Port size	Substitute
1/4	0
3/8	1
1/2	2
3/4	3
1	4
1 1/4	5
1 1/2	6
2	7
Valve options	Substitute
Normally open (NO), from G1 1/4 with solenoid 9151 0,1 ... 16 bar (1,45 ... 232 psi)	01
Manual override	02
Seat seal FPM, Fluid temperature -5 ... +110°C (+23 ... +230°F)	03
Seat seal EPDM, for hot water, max. fluid temperature +110°C (+230°F) 0,3 ... 16 bar (4,35 ... 232 psi) (up to G1) 0,3 ... 10 bar (4,35 ... 145 psi) (from G1 1/4)	14
Latching system impuls time min. 30 ms only for d.c. 6 V, 12 V and 24 V	50
Version for drinking water with test according to KTW	88

Frequency	Substitute
See table frequency codes	xx
Voltage	Substitute
See Voltage codes	xxx
Solenoid options	Substitute
G1/4 ... 1 Operating pressure 0,1 ... 16 bar (1,45 ... 232 psi)	9101
G1 1/4 ... 2 Operating pressure 0,1 ... 10 bar (1,45 ... 145 psi)	9101
G1 1/4 ... 2 Operating pressure 0,1 ... 16 bar (1,45 ... 232 psi)	9151

Standard solenoid systems

Voltage and Frequency Solenoid 9101 *1)						
Code	Code	Voltage	Frequency	Power consumption		
Voltage	Frequency			Inrush	Holding	
024	00	24 V d.c.	-	8 W	8 W	
024	50	24 V a.c.	50 Hz	15 VA	12 VA	
110	50	110 V a.c.	50 Hz	15 VA	12 VA	
120	60	120 V a.c.	60 Hz	15 VA	12 VA	
230	50	230 V a.c.	50 Hz	15 VA	12 VA	
Voltage and Frequency Solenoid 9151 *1)						
024	00	24 V d.c.	-	18 W	18 W	
024	50	24 V a.c.	50 Hz	45 VA	35 VA	
110	50	110 V a.c.	50 Hz	45 VA	35 VA	
120	60	120 V a.c.	60 Hz	45 VA	35 VA	
230	50	230 V a.c.	50 Hz	45 VA	35 VA	

\*1)  US coil only

Electrical details for all solenoid systems

<b>Design</b>	DIN VDE 0580
<b>Voltage range</b>	±10%
<b>Duty cycle</b>	100% ED
<b>Protection class</b>	EN 60529 IP65
<b>Socket</b>	Form A acc. to DIN EN 175301-803 (included)

According to DIN VDE 0580 at a solenoid temperature of +20°C.  
At operating state temperature the input power of a coil decreases by up to ca. 30% due to physical reasons.



Additional solenoid systems

ATEX category	Protection class	Solenoid	Standard voltages
II2GD	EEx m II T4 T 130°C with 3 m connection cable	9136	24 V d.c., 110 V a.c., 230 V a.c.

Attention!

The conditions imposed on the Ex approvals lead to reduction of the permissible standard temperature ranges in the cases of explosion protected solenoids.

Further versions on request!

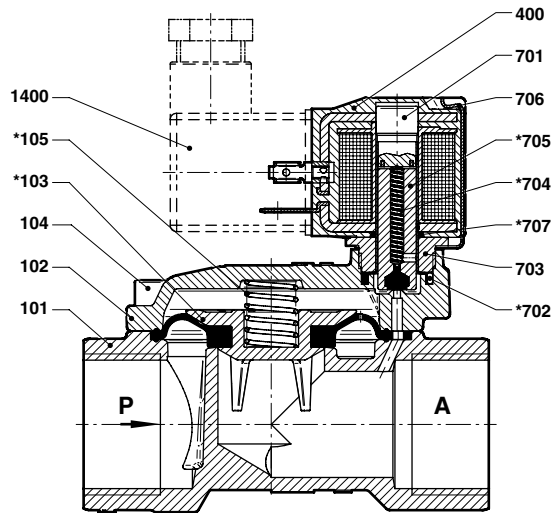
**Section View**
**G1/4 ... 1**  
**1/4 ... 1 NPT**

No.	Description
101	Valve body
102	Valve cover
*103	Diaphragm
104	Allen head screw
*105	Pressure spring
400	Solenoid
701	Core tube
*702	O-ring
703	Screw piece
*704	Pressure spring
*705	Plunger
706	Spring clip
*707	O-ring
1400	Socket (included)

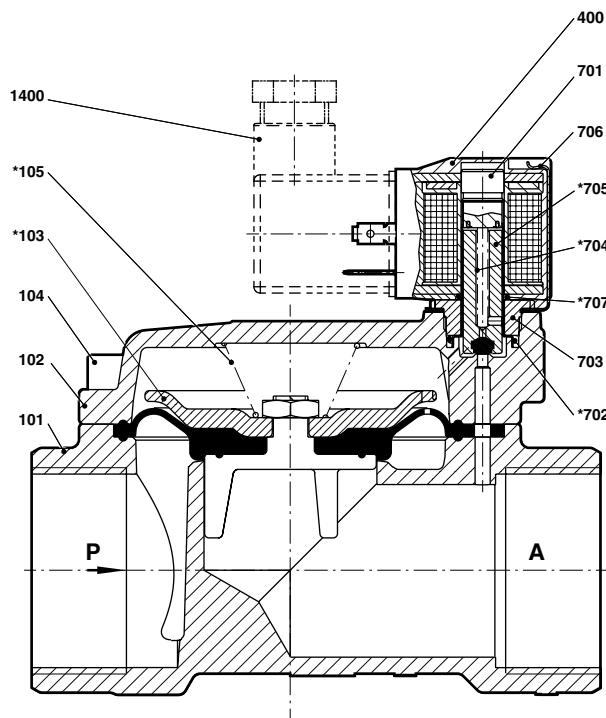
**G1 1/4 ... 2**  
**1 1/4 ... 2 NPT**

No.	Description
101	Valve body
102	Valve cover
*103	Diaphragm
104	Allen head screw
*105	Pressure spring
400	Solenoid
701	Core tube
*702	O-ring
703	Screw piece
*704	Pressure spring
*705	Plunger
706	Spring clip
*707	O-ring
1400	Socket (included)

\* These individual parts form a complete wearing unit.  
 When ordering spare parts please state Model No. and Series No.

**Dimensions**

G1/4 ... 2  
1/4 ... 2 NPT

Dimensions in mm  
Projection/First angle

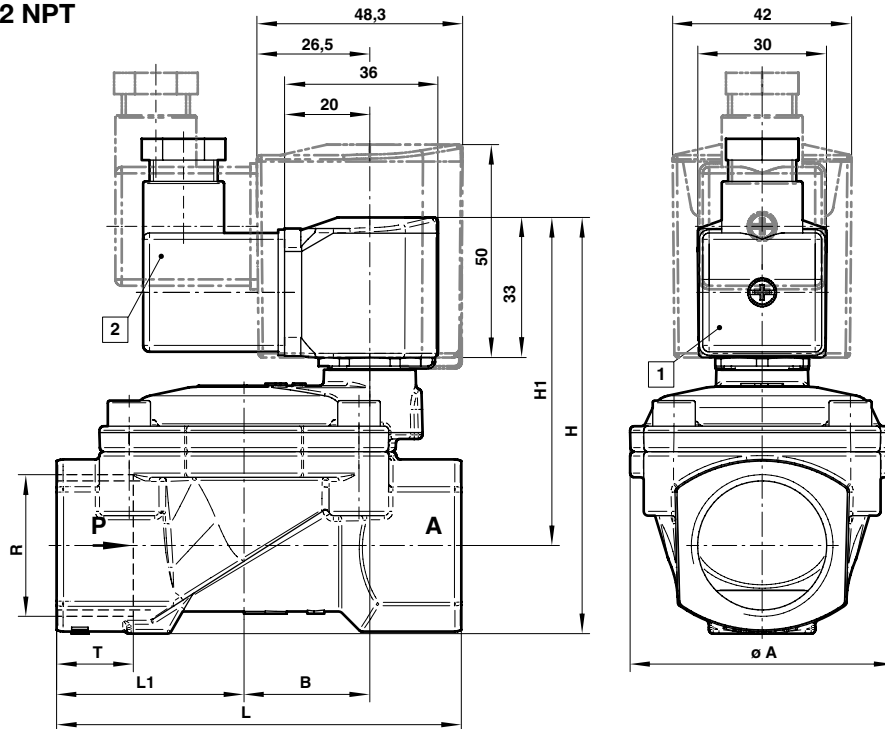
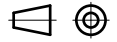

- 1 Solenoid rotatable 360°
- 2 Socket turnable 4 x 90°  
(Socket included)

Port size R	A	B	H	H1	L	L1	T	Typ
G1/4	44	19,5	78,5	67	60	27,5	12	8240000.9101.xxxxx
1/4 NPT	44	19,5	78,5	67	60	27,5	10	8241000.9101.xxxxx
G3/8	44	19,5	78,5	67	60	27,5	12	8240100.9101.xxxxx
3/8 NPT	44	19,5	78,5	67	60	27,5	10,5	8241100.9101.xxxxx
G1/2	44	19,5	81	67	67	31	14	8240200.9101.xxxxx
1/2 NPT	44	19,5	81	67	67	31	13,5	8241200.9101.xxxxx
G3/4	50	24	88	71,5	80	36,5	16	8240300.9101.xxxxx
3/4 NPT	50	24	88	71,5	80	36,5	14	8241300.9101.xxxxx
G1	62	29,5	97,5	77	95	44	18	8240400.9101.xxxxx
1 NPT	62	29,5	97,5	77	95	44	17	8241400.9101.xxxxx
G 1 1/4	92	44,5	124,5	95,5	132	60	20	8240500.9101.xxxxx
1 1/4 NPT	92	44,5	124,5	95,5	132	60	17	8241500.9101.xxxxx
G1 1/2	92	44,5	124,5	95,5	132	60	22	8240600.9101.xxxxx
1 1/2 NPT	92	44,5	124,5	95,5	132	60	17	8241600.9101.xxxxx
G2	109	54,5	142,5	108	160	74	24	8240700.9101.xxxxx
2 NPT	109	54,5	142,5	108	160	74	17,5	8241700.9101.xxxxx

**Note to Pressure Equipment Directive (PED):**

The valves of this series, including the connection size DN 25 (G 1), are according to Art. 3 § 3 of the Pressure Equipment Directive (PED) 97/23/EG. This means interpretation and production are in accordance to engineers practice wellknown in the member countries.

The CE-sign at the valve refers not to the PED. Thus the declaration of conformity is not longer applicable for this directive.

For valves > DN 25 (G 1) Art. 3 § (1) No.1.4 applies.

The basic requirements of the Enclosure I of the PED must be fulfilled. The CE-sign at the valve includes the PED. A certificate of conformity of this directive will be available on request.

**Note to Electromagnetic Compatibility Guideline (EEC):**

The valves shall be provided with an electrical circuit which ensures the limits of the harmonised standards EN 61000-6-3 and EN 61000-6-1 are observed, and hence the requirements of the Electromagnetic Compatibility Guideline (2004/108/EG) satisfield.